



PORTAFILL
CRUSHING & SCREENING SYSTEMS



www.portafill.com

PORTAFILL 2000CT	04
PORTAFILL 3000ST	06
PORTAFILL 4000W	08
PORTAFILL 4000T	10
PORTAFILL 5000CT	12
PORTAFILL 7000C	14
PORTAFILL WASH SYSTEM ..	16
PORTAFILL CONVEYORS	18

PORTAFILL 2000CT

The Portafill 2000CT is an easy to operate, compact, portable and highly reliable screening plant. Specifically designed for ease of use, with the small to medium sized contractor in mind. The 2000CT can be operational moments after arriving on site and is designed to handle heavy applications.

- Features**
- Heavy duty tracked undercarriage for ease of movement.
 - Control the machine using a hand held radio or wire remote control unit.
 - The conveyor folds from transport mode in a snap.
 - Wide main conveyor with large stockpiling capacity.
 - Optional middle product conveyor to produce a total of three products.

All dimensions are approximate and shown in millimetres or feet and inches. Subject to change without notice.

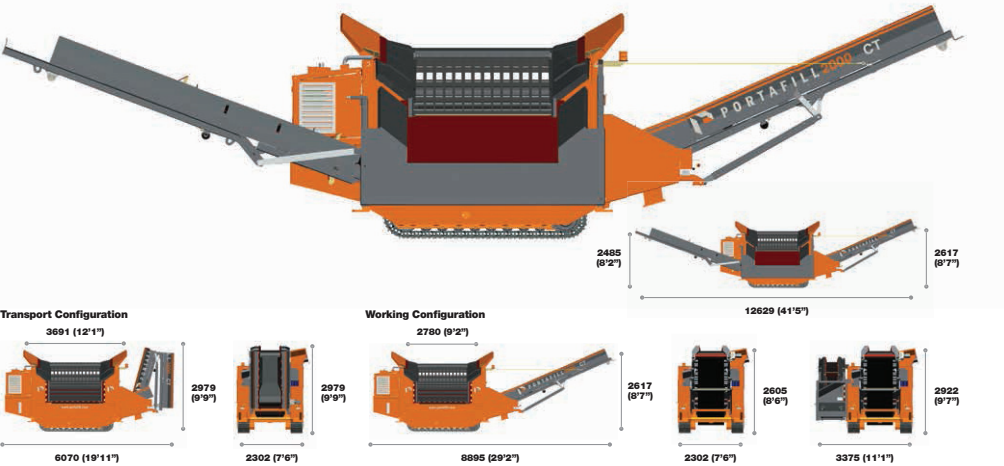

PORTAFILL 3000ST

The Portafill 3000ST is a high yield but ultra-portable screening plant. International shipping is a breeze as this powerful machine can hydraulically compact to fit inside a single shipping container or be transported by road to end users.

- Features**
- Triple conveyor system for multiple products.
 - Aggressive screening action yielding high production.
 - Track mounted for ultra-portability around site.
 - Side facing tipping grid for loading with excavator or loader.
 - Machine compacts incredibly well to aid efficient and easy transport.

All dimensions are approximate and shown in millimetres or feet and inches. Subject to change without notice.

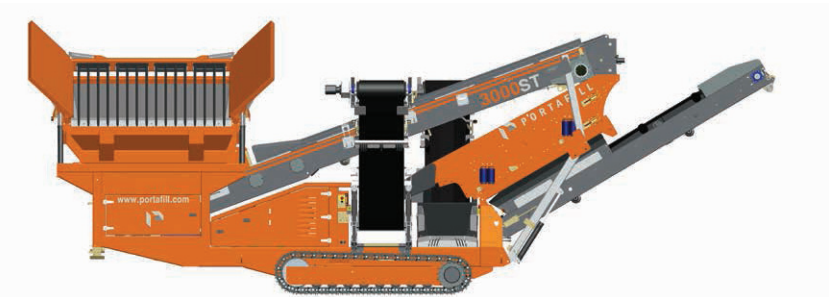

Transport Configuration

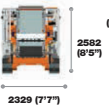
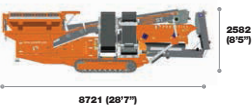

Working Configuration

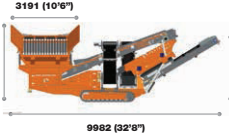

PORTAFILL 4000W

The Portafill 4000W features the latest mobile trommel screen technology for screening soil, compost, wood, landfill waste, light rubble and other material. The 4000W can be transported on its own tandem axle and can easily be transported from site to site.

Features

- Quick changeable drum to screen different fractions.
- Hydraulically folding wing and product conveyors for easy setup and tear down.
- Easy access to engine and hydraulics for servicing and maintenance.
- Self-cleaning drum action.
- Tandem axle, ABS braking and TUV Ready.

All dimensions are approximate and shown in millimetres or feet and inches. Subject to change without notice. Patent Pending EP 14151193.1

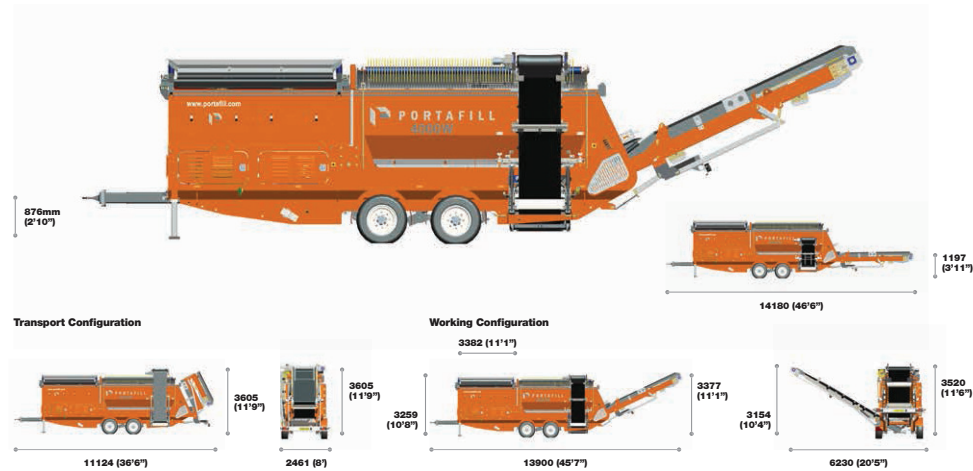

PORTAFILL 4000T

The 4000T is the tracked version of the popular 4000W trommel. Ideal for screening soil, compost, wood, landfill waste, light rubble and other material, the 4000T has a tracked undercarriage and can easily be moved around site or by trailer between sites.

Features

- Quick changeable drum to screen different fractions.
- Hydraulically folding wing and product conveyors for easy setup and tear down.
- Easy access to engine and hydraulics for servicing and maintenance.
- Self-cleaning drum action.
- Heavy duty tracked undercarriage for moving on site.

All dimensions are approximate and shown in millimetres or feet and inches. Subject to change without notice. Patent Pending EP 14151193.1

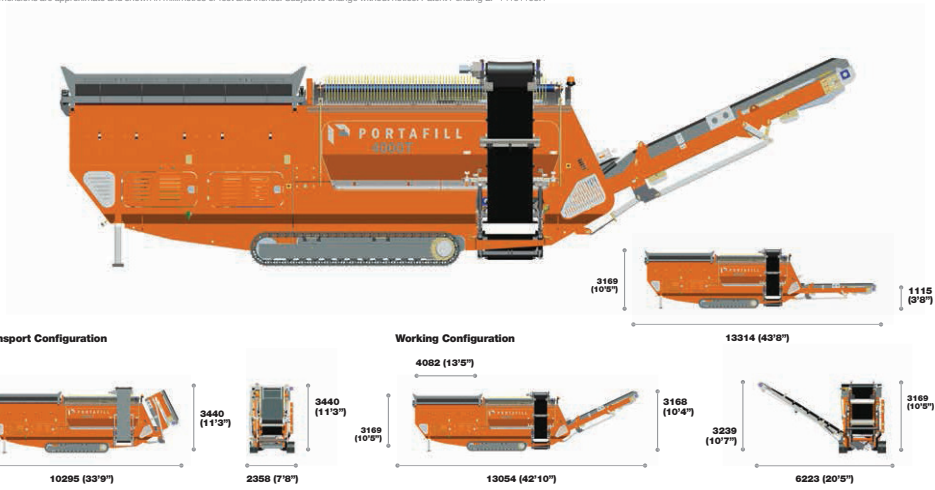

PORTAFILL 5000CT

The Portafill 5000CT is designed with heavy duty screening applications in mind. Small enough to fit inside a container for transport but strong enough to withstand the toughest of materials. High performance, excellent reliability. This machine can be used in a very wide variety of applications.

- Features**
- Highly aggressive screen action for excellent performance in difficult materials.
 - Folding wing conveyors with large stockpile capacity.
 - 2m³ oversize product conveyor for optionally mixing oversize and middle product.
 - Heavy duty tracks for moving across rough terrain.
 - Low fuel consumption for low cost of ownership.

All dimensions are approximate and shown in millimetres or feet and inches. Subject to change without notice.

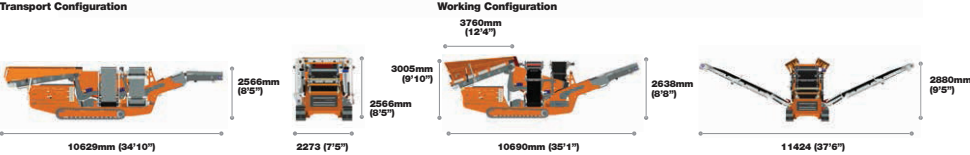
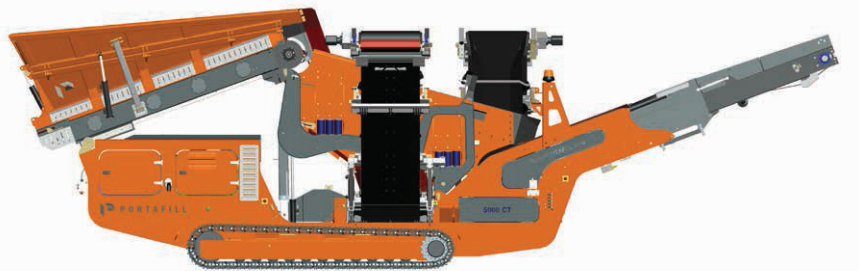

PORTAFILL 7000IC

The Portafill 7000IC is a modern compact impact crusher, ideally suited to crush concrete, rubble, asphalt and stone. It's low running costs and ease of operation make it a must have piece of equipment for contractors and recycling operators. The 7000IC can be fitted with a screen and recycling conveyor system that returns oversized material to the crushing unit. The complete assembly can easily be folded for transport.

Features

- Vibrating feeder with load sensing for controlled crushing.
- High capacity impact crusher.
- Blockage release mechanism on crusher.
- Low fuel consumption for low cost of ownership.
- Overband magnet on main conveyor for removal of metals.

All dimensions are approximate and shown in millimetres or feet and inches. Subject to change without notice. Images show 7000IC with screen and recirculating conveyor system. Patent Pending EP 14151188.1 & EP 13197036.0

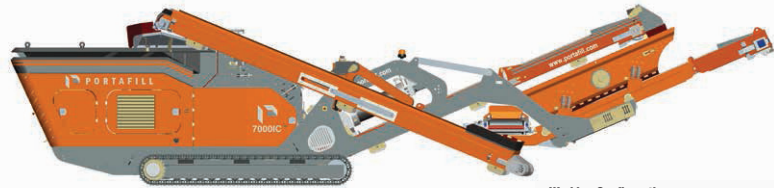

Working Configuration



13988 (45'10")

Transport Configuration



11886 (39')



2300 (7'6")

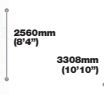

3308mm (10'10")

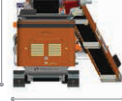

3759 (12'4")



5373 (17'7")



PORTAFILL WASH SYSTEM

Portafill International offer a complete wash system to meet the needs of small to medium size aggregate producers. The Portafill 3000ST can be fitted with double wash decks with the sand slurry mix being fed into the Portafill DW80 dewaterer. Water can be lifted to the wash decks using the water pump power pack.

- Features**
- Self-contained diesel power pack with water pump to feed water to screen.
 - Twin wash decks fitted to screen of Portafill 3000ST.
 - Sand and water collected via sand box and fed to Portafill DW80 dewaterer.
 - Single wheel dewaterer for capturing washed sand.
 - Portafill 3000ST, Powerpack and DW80 can fit inside container for easy transport.
 - Ideal solution for small to medium sized sand and gravel producer.

All dimensions are approximate and shown in millimetres or feet and inches. Subject to change without notice.

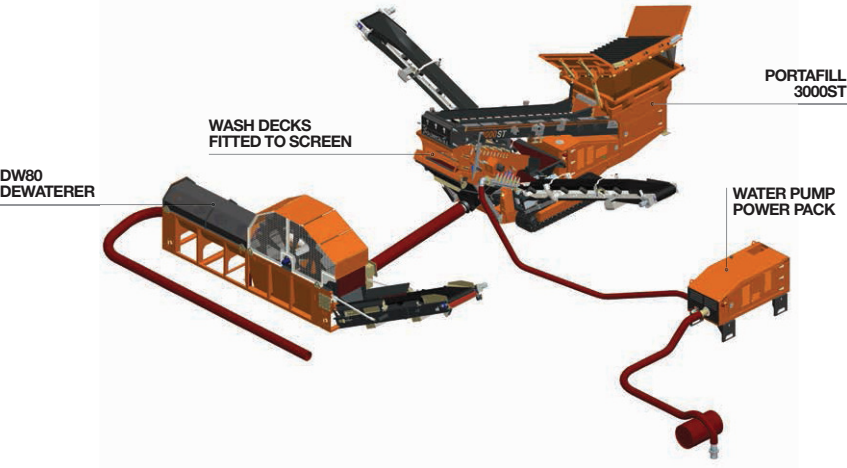

PORTAFILL CONVEYORS

Portafill International have a range of tracked and wheeled conveyors to complement our range of mobile compact screens. These conveyors maximise production of the Portafill screens and are a great option for any stockpiling requirements you have.

- Features**
- Full size range of tracked and wheeled stacking conveyors.
 - Adjustable feed and discharge heights.
 - Dig seat/remote control.
 - Hydraulic folding for container transport.
 - Full range of options including dual power diesel or electric.

All dimensions are approximate and shown in millimetres or feet and inches. Subject to change without notice. Patent Pending EP 13197031.1

Tracked Conveyors

Model	Length (A)	Height (B)
TC80	15.3m (50'2")	6.8m (22'3")
TC90	18.3m (60')	8m (26'3")
TC90	22.8m (74'9")	10.7m (35'1")



Radial Conveyors

Model	Length (A)	Height (B)
CW56	15.3m (50'2")	7.5m (24'7")
CW65	19.8m (65'1")	9.4m (30'9")
CW80	22.8m (75'9")	11m (36'1")



Dealer Details:

29 Farrifer Road, Cabragh, County Tyrone, N. Ireland, BT70 1TL
T: 44 (0)28 8776 9467 | reception@portafill.com | www.portafill.com